

Colour Code of Innerconductors (F-PE Isolation)

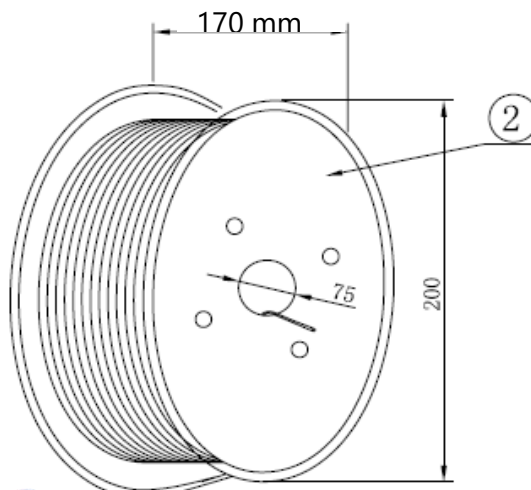
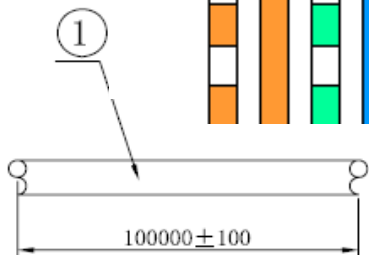
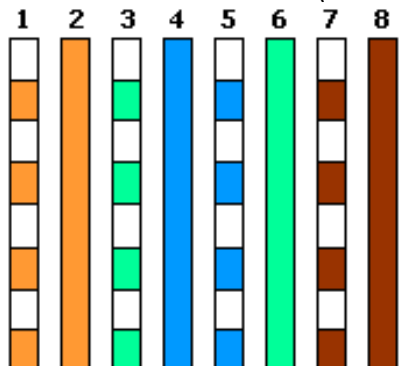

Cat. 7A+ network cable, field of application: indoor structured cabling.

- Specification: Cat. 7A+ (Class FA)
- Transmission frequency up to: 1200MHz
- Bandwidth up to: 10Gbps

- Number of shieldings: 2
- Shielding 1: ALU foil laminated PIMF (100% density)
- Shielding 2: tinned copper braid
- Shielding class: S/FTP
- Cable structure: AWG 22/1
- Wire material: copper
- Wire type: solid
- Wire number: 8 (4 x 2 twisted pair)

- Cable type: round cable
- Material cable sheath: LSZH (halogenfree)
- Diameter cable (ca.): 8.2mm
- CPR Euroclass: B2ca-s1a,d1,a1

- Color cable: yellow
- Winding: paper spool



LENGTH: 100M/Paper Disk

Cable with Metermarking

3	Imprint	Cat. 7A+ S/S/FTP AWG 22/1 LSZH 100 OHM IEC 61156-7 CE Euro-class B2ca NB 2479 (26/19)
2	Jacket	OD = 8,2 mm - LSZH - yellow RAL 1026
1	Cable	Braiding 40x0,10mm Tinned Copper - Innerconductor AWG22/1 Bare Copper - PIMF
NO	PARTS	DESCRIPTION

CPR Euroclass B2ca

<p>Media Connect Distribution GmbH Gösggerstrasse 13, 5012 Schönenwerd 062 858 80 00, auftrag@kabelschweiz.ch</p>		DESCRIPTION		INSTALLATION CABLE CAT 7A+ S/FTP PIMF LSZH			
		SIZE	A4	DATE	17.09.20203	CHECKED	
UNIT	MM	DRAWN	R. Hueller	APPROVED			
CUSTOM TARIF NO.: 85444920000							

5pcs in 1 Carton with Innercartons -
Cable is on Paperspool with Plastic -
Innercircle

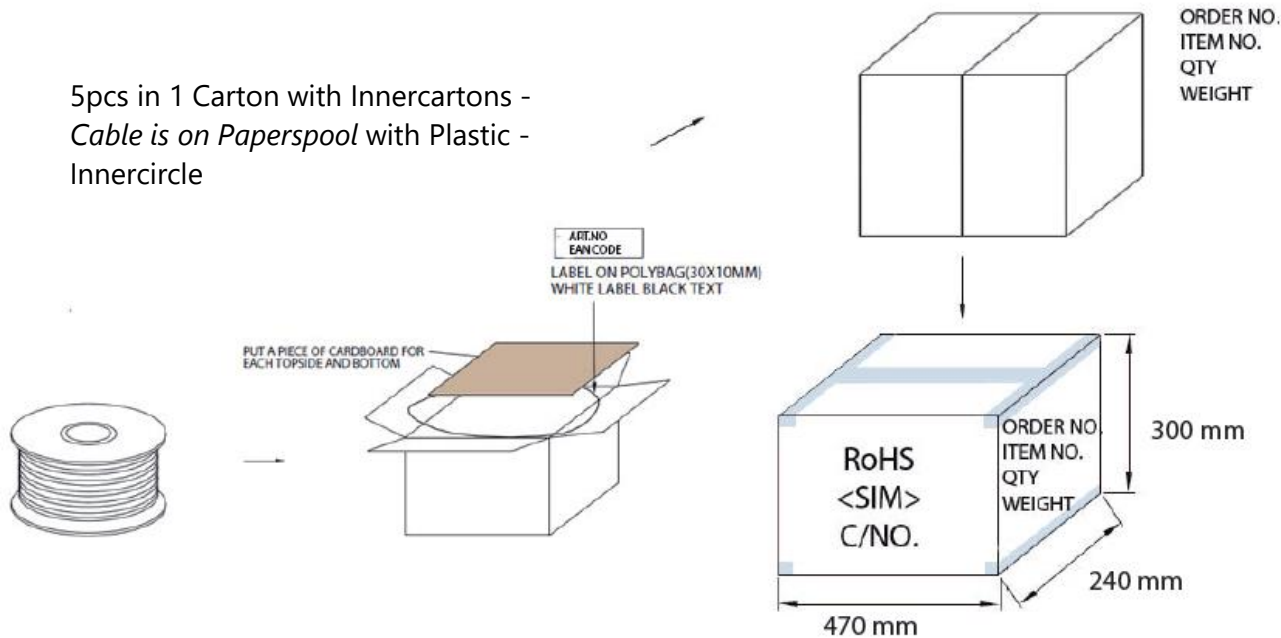

Only use strong Cartons with printed letters
Handwritten not allowed !!!

ART. NO.	LENGTH	ROLLING SIZE	NET.WEIGHT	PACKING	EAN CODE
90-98084	25m			16 EXP - 1 pc in stretchfoil with st.	4017538144959
90-98085	50m			4 EXP - 1 pc in stretchfoil with st.	4017538144966
75500-A+-100SSP	100m	270x270x160mm	6000g	2 EXP - 1 pc in stretchfoil with st.	4017538115553
75500-A+-500S	500m	535x535x220mm	30050g	1 pc in stretchfoil with st.	4017538115577

kabelschweiz.ch

Media Connect Distribution GmbH
Gösggerstrasse 13, 5012 Schönenwerd
062 858 80 00, auftrag@kabelschweiz.ch

DESCRIPTION

INSTALLATION CABLE CAT 7A+ S/FTP PIMF LSZH

SIZE	A4	DATE	17.09.2023	CHECKED		TOL	75500-A+-S
UNIT	MM	DRAWN	R. Hueller	APPROVED			
CUSTOM TARIF NO.: 85444920000							